

Mark a 60° degree angle on each end.
Saw off angle.

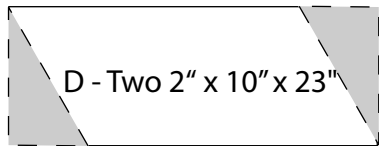

Mark a 60° degree angle on each end.
Saw off angle.

Leopold Bench

To make one of these benches, you will need the following materials:

Wood:

- A - One 2" x 10" x 51" - bench back
- B - One 2" x 10" x 48" - bench seat
- C - Two 2" x 10" x 38" - bench side panels
- D - Two 2" x 10" x 23" - bench legs

Hardware:

- Six 3/8" x 3-1/2" carriage bolts with washer and nut
- Twelve 3/8" x 3-1/2" #12 or #14 flathead wood screws (to secure bench back and seat)

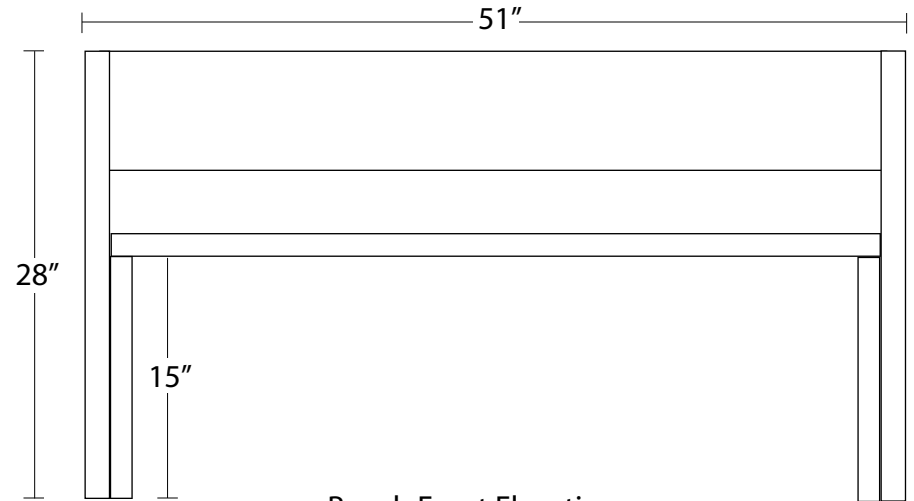

Bench Front Elevation

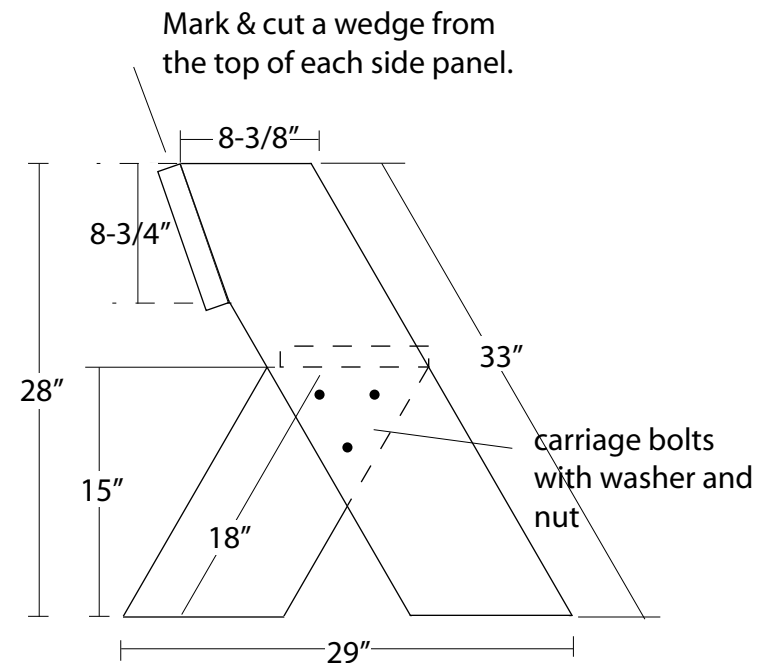

Bench Side Elevation